

CIP Training

Pro C5300 series

RICOH
imagine. change.

1 Input

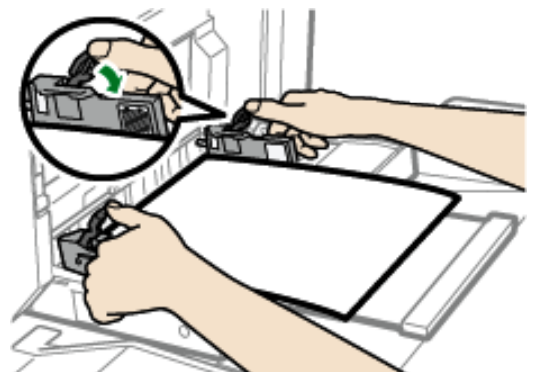
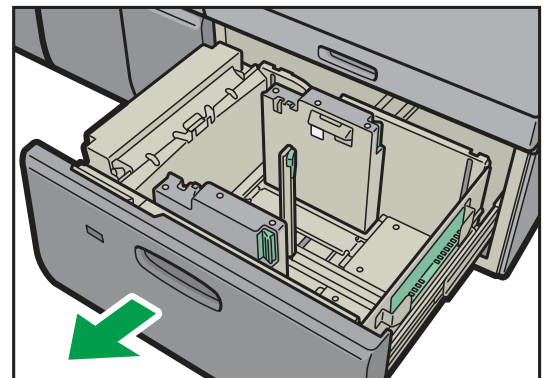
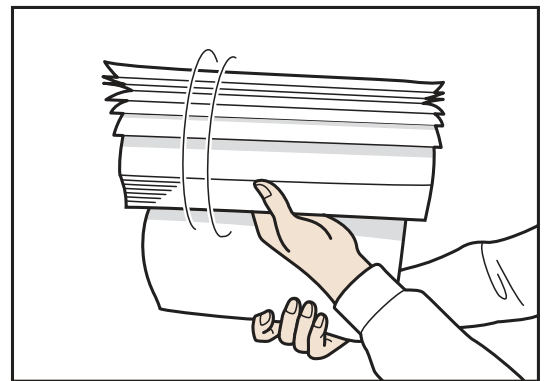

Loading Paper

Loading Paper into the Paper Tray

The method of loading paper varies for each tray type.

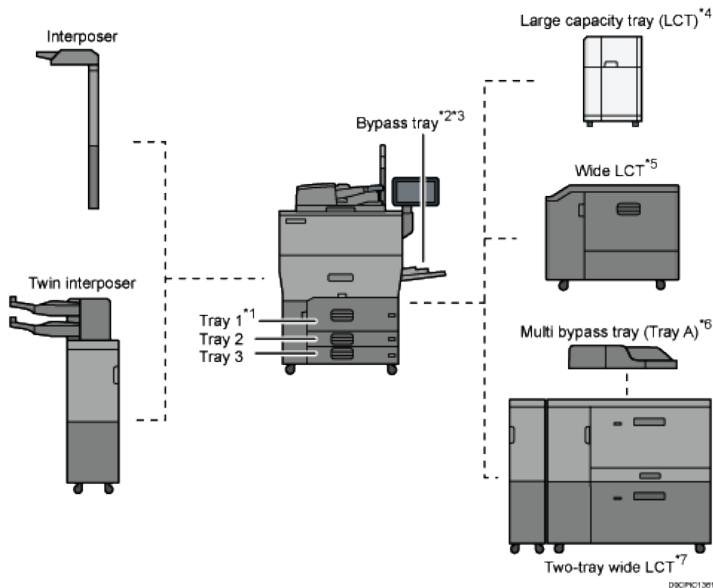

- *1 The A3/11 × 17 tray unit can be attached.
- *2 The banner paper guide tray can be attached.
- *3 This is unavailable if the two-tray wide LCT is attached.
- *4 The extension unit of LCT can be attached.
- *5 The banner sheet guide tray can be attached.
- *6 The banner sheet tray of multi bypass tray (Tray A) can be attached.
- *7 The banner sheet tray of two-tray wide LCT can be attached.

Note

- Before loading paper into a tray, check the paper size and type that can be loaded in the tray, and confirm the paper size that is automatically detected.
- When loading paper of a size that is not automatically detected, specify the paper size in [Tray Paper Settings].
- Check the paper setting before printing. If the paper differs from the paper setting, a mismatch error will occur when you print.
- Straighten curled or warped paper before loading.
- When loading paper on a tray which has a few sheets of paper, multiple sheets of paper may be fed at once from the tray. Take out all sheets, fan the sheets, and then load them again.
- You may hear the sound of rubbing paper. This is not a malfunction.
- Do not stack paper over the limit mark.



Loading Paper

★ Important

- **Do not stack paper over the limit mark**

Jams and misfeeds can occur when printing on thick glossy sheets. To prevent such problems, be sure to fan glossy sheets thoroughly before loading them.

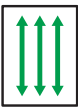
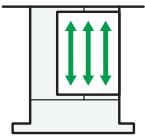
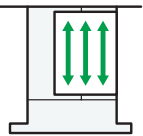
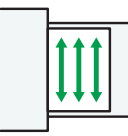
When loading paper, set the paper direction according to its grain, as shown in the following diagram:

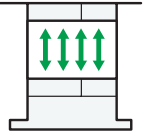
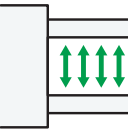
Direction of paper grain	Tray 1	A3/11 × 17 tray unit, Tray 2, or the wide LCT	Multi bypass tray (Tray A)
			
	Not recommended		

↓ Note

- Even if paper is loaded as described above, normal operations and print quality might still not be possible, depending on the paper type.
- When loading 52.3 g/m² (14.0 lb. Bond) paper into paper trays or loading translucent paper into the wide LCT or the multi bypass tray (Tray A), always use long grain paper.
- To prevent multiple sheets from being fed at once, fan the paper before loading it.
- If you load paper when only a few sheets of paper remain in the tray, multiple sheet feeding may occur. Remove any remaining paper, stack them with the new sheets of paper, and then fan the entire stack before loading it into the tray.
- Straighten curled or warped paper before loading.
- When paper in trays that are set to automatically eject unnecessary tab stock sheets runs out, reload the tab stock from the beginning of the cycle (the first sheet).
- When you load paper into the paper tray for the first time or when you change the size or type of paper in the paper tray, be sure to specify the appropriate paper settings in Tray Paper Settings.
- You might at times hear a rustling noise from paper moving through the machine. This noise does not indicate a malfunction.

Loading Paper

1. Loosen the stack by riffling the sheets.

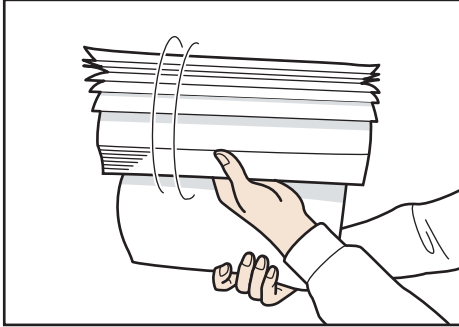

2. Holding its shorter ends, flex the stack back and forth to create space between the sheets. Repeat this several times.

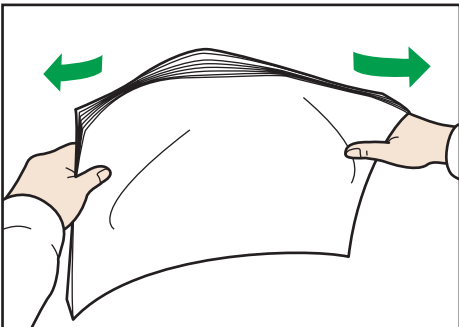
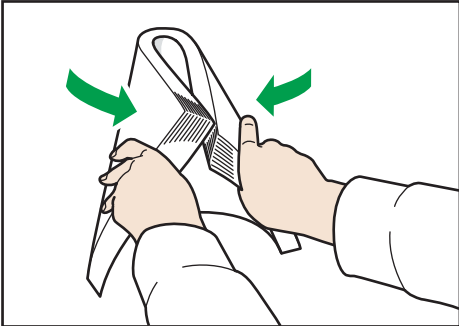

3. Make sure there is space between the sheets.

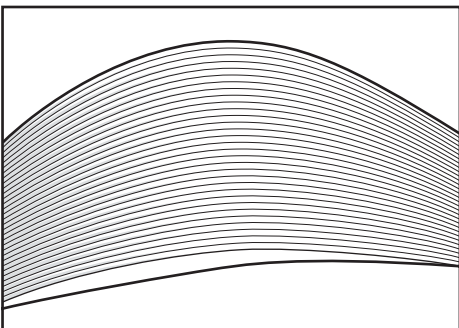

Loading Paper Tray 1

- Tray 1 can hold **A4** paper only or can be fitted with an optional **A3** tray.
- When paper loaded in the right side of Tray 1 runs out, paper on the left is automatically shifted to the right. Do not pull out Tray 1 while the tray is moving paper; wait until sound stops coming from the tray.
- If Tray 1 is closed too quickly, the paper in the tray may force the right tray's side fence to slip out of place. If the paper misfeeds because of this, open the tray, adjust the fence, and close the tray slowly.
- For the right stack, align the right edge of the paper with the right edge of the tray. For the left stack, align the left edge of the paper to the left edge of the tray.

Step: 1

Carefully pull out the paper tray until it stops.

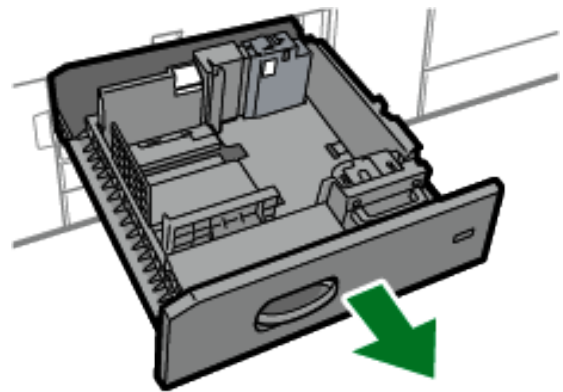

DOC PRO 1312

Step: 2

Square the paper and load it print side down.

Do not stack paper over the limit mark of both trays.



DOC PRO 1295

Whole tray pulled out.

Loading Paper Tray 1

Step: 3

Carefully push the paper tray fully in.

Specify the paper settings.

NOTE: You can load paper even if Tray 1 is in use. It is okay to pull out the left half of the tray while Tray 1 is in use.



0000001200

Left half of the tray pulled out.

Specifications.

Capacity: 2,500 sheets (A4) 1,250 per tray. (based on using 80gsm uncoated paper)

Weight: Paper weight 1: 52.3 to 65.9 gsm Paper weight 5: 127.5 to 150.0 gsm
Paper weight 2: 66.0 to 80.9 gsm Paper weight 6: 150.1 to 216.0 gsm
Paper weight 3: 81.0 to 100.9 gsm Paper weight 7: 216.1 to 256.0 gsm
Paper weight 4: 101.0 to 127.4 gsm Paper weight 8: 256.1 to 300.0 gsm

Paper Type Plain Paper, Recycled Paper, Black, Color, Letterhead, Preprinted Paper,
Prepunched Paper, Textured Paper

CIP Training Pro C5300 series

*Loading Paper A3 Tray 1

*Optional A3, Tray 1:

Check that paper in the paper tray is not being used, and then pull the tray carefully out until it stops.

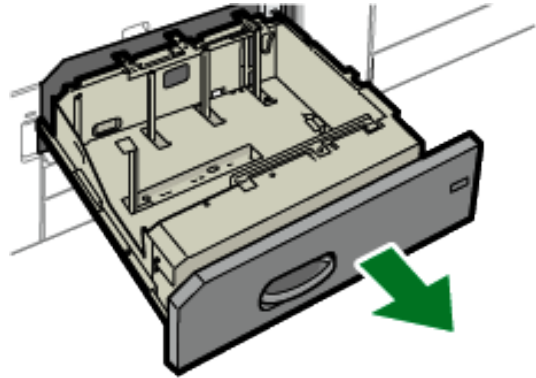

DOC M01313

Square the paper and load it print side down.

- Do not stack paper over the limit mark.

Carefully push the paper tray fully in. Specify the paper settings.

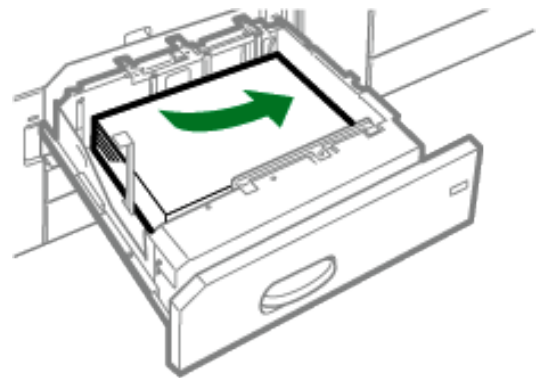

DOC M01314

Specifications.

Capacity: 1,250 sheets **A3** (based on using 80gsm uncoated paper)

Weight:	Paper weight 1: 52.3 to 65.9 gsm	Paper weight 5: 127.5 to 150.0 gsm
	Paper weight 2: 66.0 to 80.9 gsm	Paper weight 6: 150.1 to 216.0 gsm
	Paper weight 3: 81.0 to 100.9 gsm	Paper weight 7: 216.1 to 256.0 gsm
	Paper weight 4: 101.0 to 127.4 gsm	Paper weight 8: 256.1 to 300.0 gsm

Paper Type: Plain Paper, Recycled Paper, Black, Colour, Letterhead, Preprinted Paper, Prepunched Paper, Textured Paper.

Loading Paper Trays 2 & 3

- Check the paper edges are aligned at the right side.
- If a paper tray is pushed vigorously when putting it back into place, the position of the tray's side fences may slip out of place.
- When loading a low number of sheets, be sure not to squeeze the side fences in too tightly. If the side fences are squeezed too tightly against the paper, the edges may crease, the paper may misfeed, or if it weighs between 52.3–63.0gsm, it may wrinkle.
- Do not stack paper over the limit mark. If you load paper over the limit mark, the printed images may become slanted or a paper jam may occur.

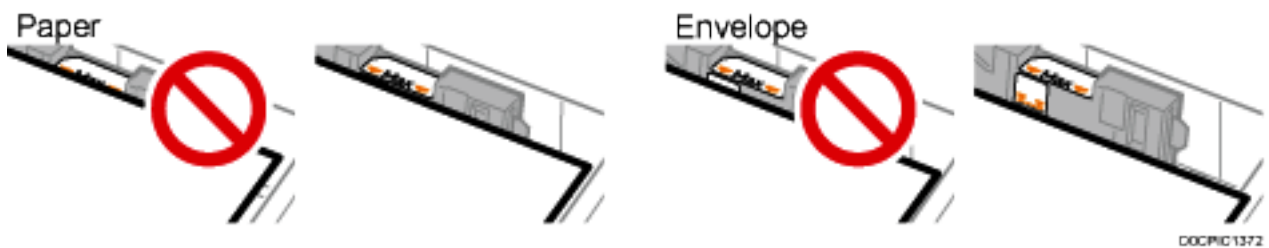

Step: 1

Check that paper in the paper tray is not being used, and then pull the tray carefully out until it stops.

Remove paper if loaded.

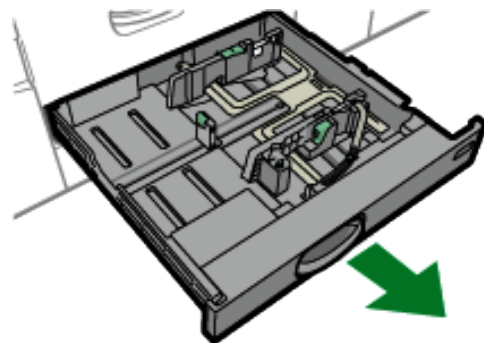

Step: 2

Release the lock on the side fence.

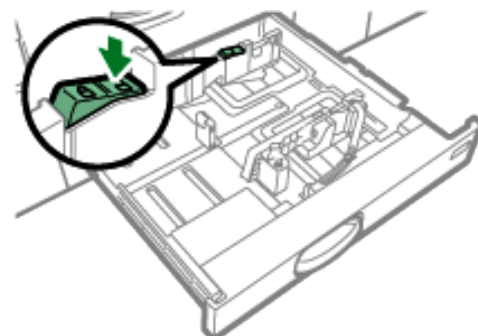

Loading Paper Trays 2 & 3

Step: 3

Loosen the screws holding the side fences in position.

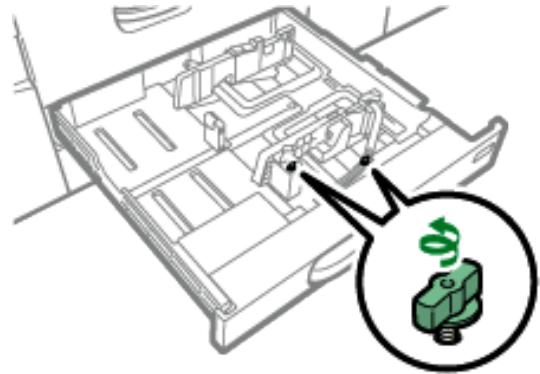

DOC P/C 1370

Step: 4

While pressing down the release lever of the side fence, slide the side fences outward.

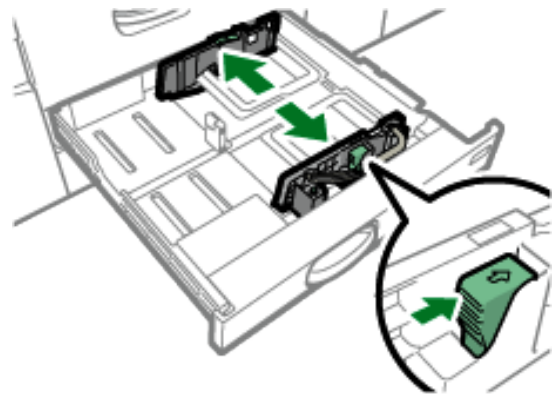

DOC P/C 1319

Step: 5

While pinching the release lever of the end fence, slide the end fence outward.

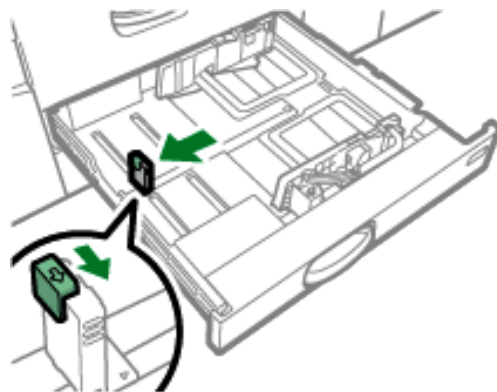

DOC P/C 1320

Loading Paper Trays 2 & 3

Step: 6

Square the paper and load it print side down.

- Do not stack paper over the limit mark.

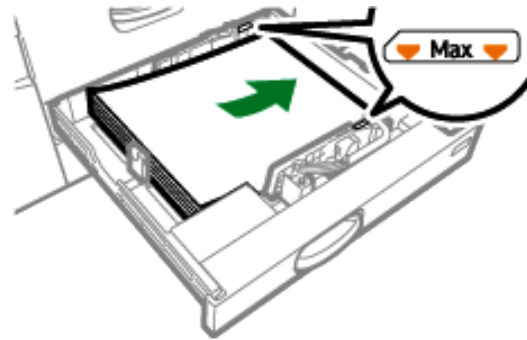

DOC PRO 13321

Step: 7

Align the end and side fences gently against the paper you loaded.

Make sure that there is no space between the paper and the side fences or end fence.

When loading thin paper, keep the gap between the paper and each side fence within 0.5 mm. If the gap is too wide, creases may occur.

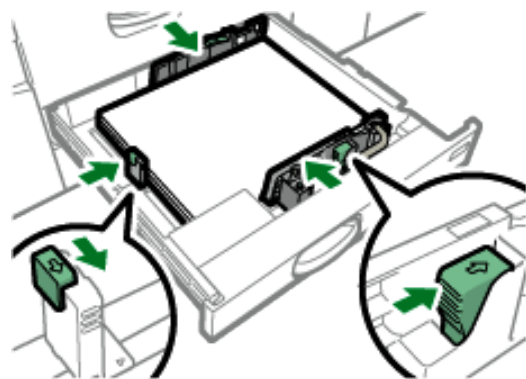

DOC PRO 13322

Step: 8

Turn the screws slowly to fasten it in place.

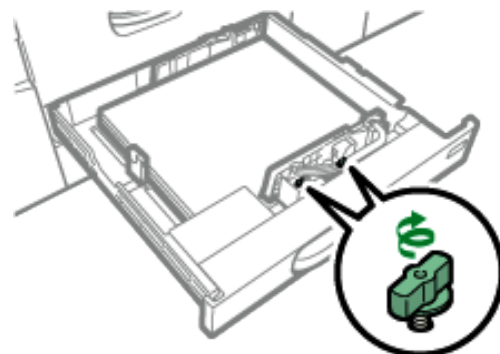

DOC PRO 13371

Loading Paper Trays 2 & 3

Step: 9

Re-lock the side fences.
Make sure there are no gaps between the paper and side fences or end fence.

Carefully slide the paper tray fully in.

NOTE: After sliding the paper tray in, make sure that the paper size is changed correctly on the printer's initial screen.

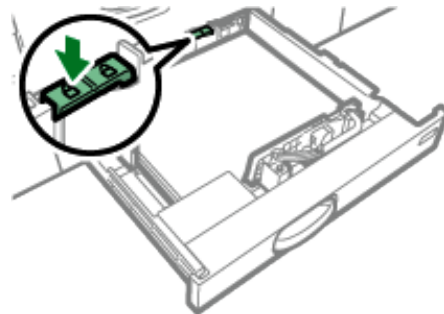

DCC-PC1333

Loading Tab stock into Trays 2 & 3

When loading tab stock, always use the optional tab sheet holder.

Load tab stock so that the side with the tab faces the tab sheet holder.

Pressing the release lever, adjust the end fence position so that the tab sheet holder fits against the tab stock.

Specify the paper settings before you start printing.

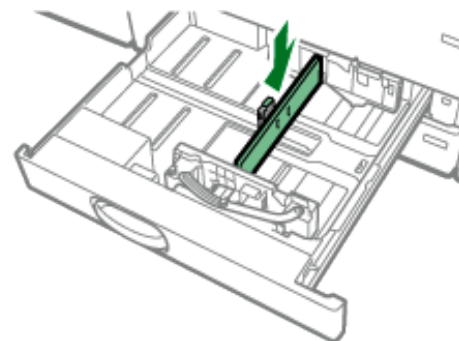

DCC-PC1317

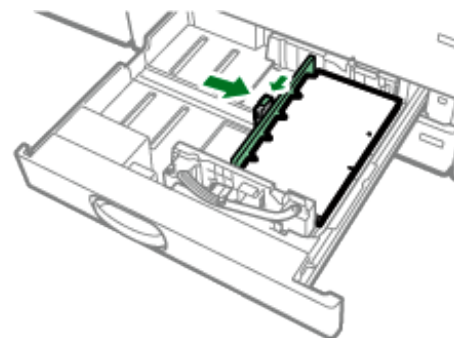

DCC-PC1318

Specifications.

Capacity: 550 sheets. (based on using 80gsm uncoated paper)

Weight:	Paper weight 1: 52.3 to 65.9 gsm	Paper weight 5: 127.5 to 150.0 gsm
	Paper weight 2: 66.0 to 80.9 gsm	Paper weight 6: 150.1 to 216.0 gsm
	Paper weight 3: 81.0 to 100.9 gsm	Paper weight 7: 216.1 to 256.0 gsm
	Paper weight 4: 101.0 to 127.4 gsm	Paper weight 8: 256.1 to 300.0 gsm

Paper Type: Plain Paper, Recycled Paper, Black, Colour, Letterhead, Preprinted Paper, Prepunched Paper, Transparency, Tab Stock (when using Tab holder, see illustration below), Translucent Paper, Textured Paper

Loading Paper into the Bypass Tray

Use the bypass tray to use transparencies, adhesive labels, translucent paper, and paper that cannot be loaded in the paper trays.

The maximum number of sheets you can load at the same time depends on paper type.

★ Important

- Do not stack paper over the limit mark. If you load paper over the limit mark, the print image may be slanted or the paper may be jammed.

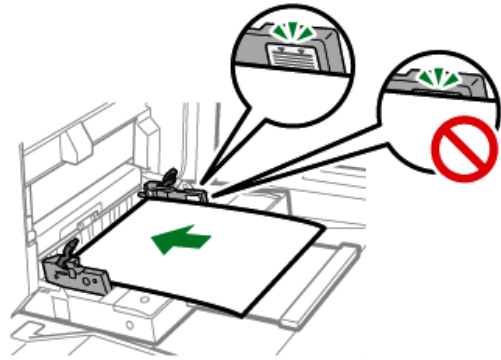

06CPC1273

Step: 1

Open the bypass tray.

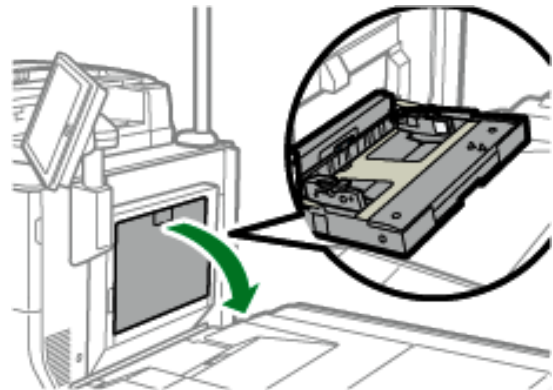

06CPC1279

Step: 2

Pull the extender out when loading paper whose size is larger than A4 Landscape.

Step: 3

Pull the extender out when loading paper whose size is larger than A4 Landscape.



06CPC1349

Loading Paper into the Bypass Tray

Step: 4

Insert the paper print side up as far as it will go into the machine.

- Fan sheets before loading so that multiple sheets of paper do not stick to each other and are not fed at once.
- When loading envelopes or letterhead paper, confirm the orientation, face and back, or location of flaps.

Step: 5

Put your fingers on the dimples on the front and rear paper guides and align the paper guides to the paper size.

- If the guides are not flush against the paper, images might be skewed or paper misfeeds might occur.

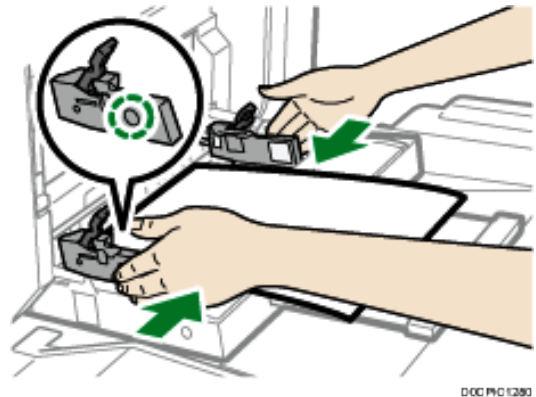

Step: 6

While holding the paper guides with your hands, lock both of the paper guides again.

- Make sure that the total of the gaps between the paper and the front and rear paper guides does not exceed 0.75 mm.

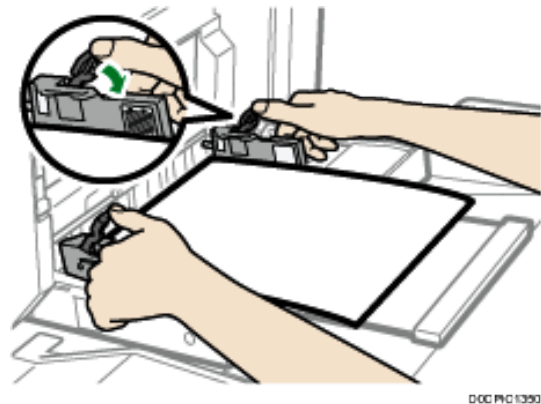

Step: 7

Specify the paper settings.

Loading Paper into the Bypass Tray

Note

- To load paper on the bypass tray, it is better to orient it in the direction of Landscape.
- Certain types of paper might not be detected properly when placed on the bypass tray. If this happens, remove the paper and place it on the bypass tray again.
- You do not need to pull the extender out if the banner sheet guide tray is installed.
- To load paper whose horizontal length is longer than 487.7 mm, the multi bypass banner sheet tray or banner sheet guide tray is needed.

Specifications.

Capacity: 250 sheets. (based on using 80gsm uncoated paper)

Weight: Paper weight 1: 52.3 to 65.9 gsm Paper weight 6: 150.1 to 216.0 gsm
Paper weight 2: 66.0 to 80.9 gsm Paper weight 7: 216.1 to 256.0 gsm
Paper weight 3: 81.0 to 100.9 gsm Paper weight 8: 256.1 to 300.0 gsm
Paper weight 4: 101.0 to 127.4 gsm Paper weight 8: 300.1 to 360.0 gsm
Paper weight 5: 127.5 to 150.0 gsm

Paper Type: Plain Paper, Recycled Paper, Black, Colour, Letterhead, Preprinted Paper, Prepunched Paper, Transparency, Tab Stock (when using Tab holder, see illustration below), Translucent Paper, Textured Paper

Loading Tab Stock in the Bypass Tray

When loading tab stock, load tab stock so the tabs face to the right.

Specify the paper settings before you start printing.

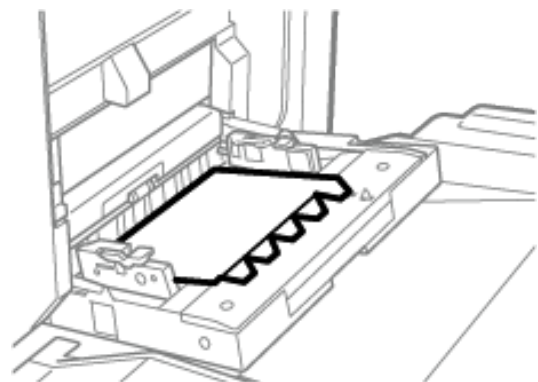

Loading Paper into the Multi Bypass Banner Sheet Tray

The multi bypass banner sheet tray can be attached to the bypass tray. This allows you to load paper having a horizontal dimension of 487.8 mm or greater in the bypass tray.

Step: 1

Pull out the multi bypass banner sheet tray.

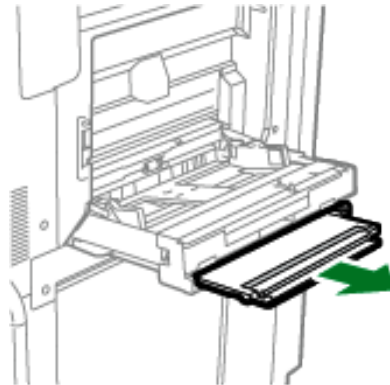

D00 P01400

Step: 2

After pulling out the multi bypass banner sheet tray, lift it until it clicks.

- Raise the multi bypass banner sheet tray until it is at an angle of about 60 degrees with the floor.

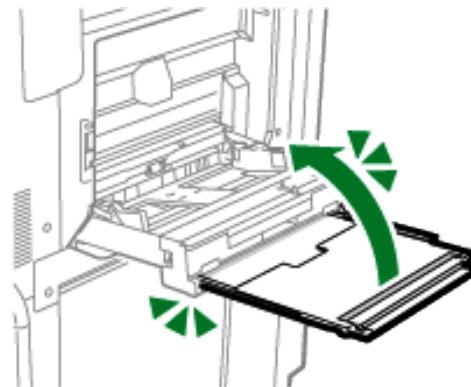

D00 P01401

Step: 3

Open the extender.

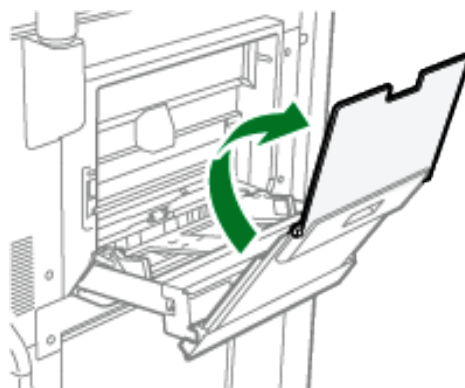

D00 P01402

Loading Paper into the Multi Bypass Banner Sheet Tray

Step: 4

Release the locks on both of the paper guides.

- Move the paper guides in the same way as when loading paper in the bypass tray.

Step: 5

Insert the paper print side up as far as it will go into the machine

Step: 6

Put your fingers on the dimples on the front and rear paper guides and align the paper guides to the paper size.

- If the guides are not flush against the paper, images might be skewed or paper misfeeds might occur.

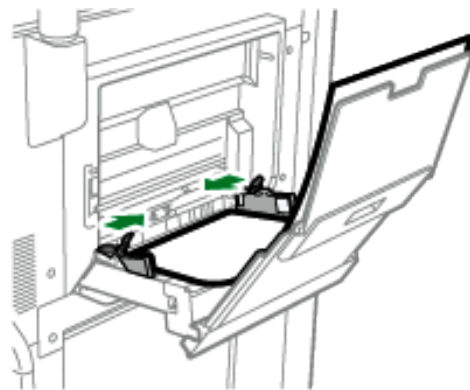

DOC PNC1403

Step: 7

While holding the paper guides with your hands, lock both of the paper guides again.

- Make sure that the total of the gaps between the paper and the front and rear paper guides does not exceed 0.75 mm.
-

Loading Paper into the Multi Bypass Banner Sheet Tray

Closing the Multi Bypass Banner Sheet Tray

Step: 1

Lightly pull up the extender, and then fold it into the machine.

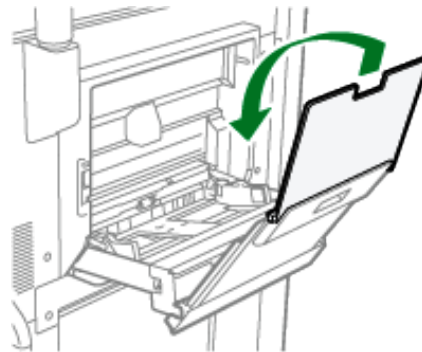

DCC-PC1404

Step: 2

Raise the multi bypass banner sheet tray towards the machine until it clicks, and then tilt it to the opposite side.

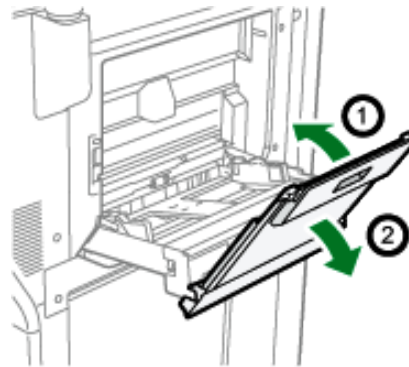

DCC-PC1405

Step: 3

Push the multi bypass banner sheet tray into its original position.

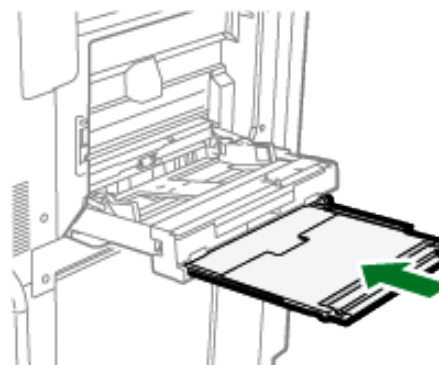

DCC-PC1406

*Loading Paper into the Banner Sheet Guide Tray

* Optional.

The banner sheet guide tray can be attached to the wide LCT. This allows you to load paper having a horizontal dimension of 487.8 mm or greater in the bypass tray.

Step: 1

Raise the multi bypass banner sheet
Open the bypass tray.

- Be careful not to get your hand caught between the bypass tray and banner sheet guide tray.

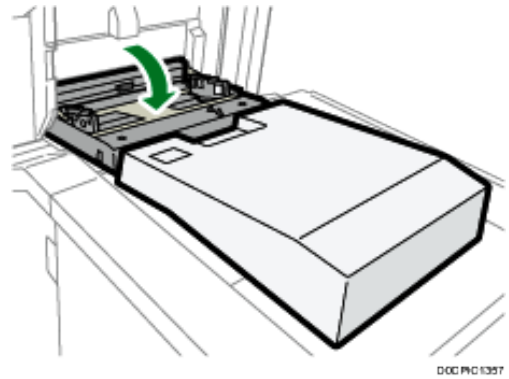

Step: 2

Release the locks on both of the paper guides.

- Move the paper guides in the same way as when loading paper in the bypass tray.

Step: 3

Insert the paper print side up as far as it will go into the machine.

- To load paper on the banner sheet guide tray, load it over the joint line of the bypass tray and the banner sheet guide tray.

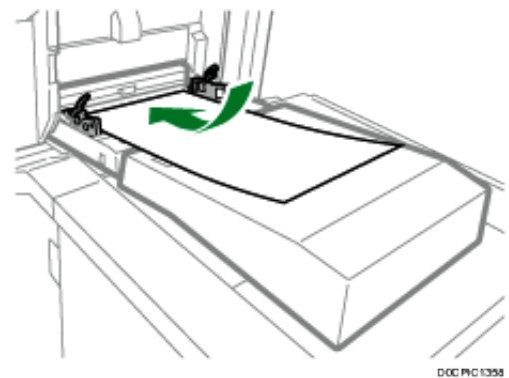

Step: 4

Put your fingers on the dimples on the front and rear paper guides and align the paper guides to the paper size.

- If the guides are not flush against the paper, images might be skewed or paper misfeeds might occur.

While holding the paper guides with your hands, lock both of the paper guides again.

- Make sure that the total of the gaps between the paper and the front and rear paper guides does not exceed 0.75 mm.

Specify the paper settings.

Loading Paper into wide LCT

Various sizes of paper can be loaded in the wide LCT by adjusting the positions of side fences and end fence.

★ Important

- Check that the paper edges are aligned with the left side.
- When loading translucent paper, always use long grain paper, and set the paper direction according to the grain.

Step: 1

Check that paper in the paper tray is not being used, and then pull the tray carefully out until it stops.

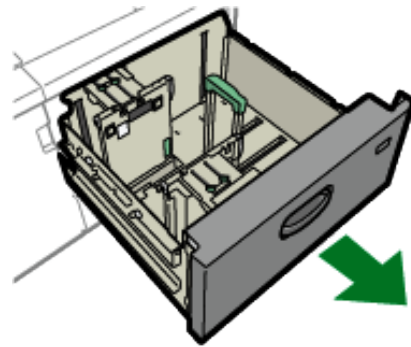

DCOMFC1285

Step: 2

Remove paper if loaded.

Step: 3

Loosen the screws holding the side fences in position.

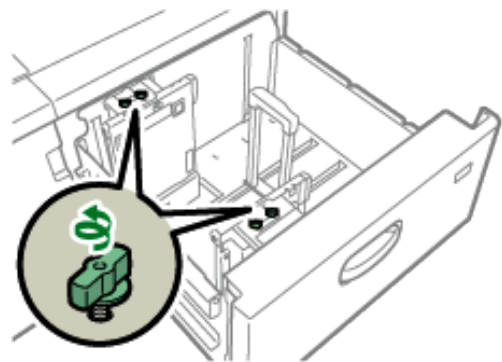

DCOMFC1285

Step: 4

Holding the labeled parts of the side fences, slide the fences outward.

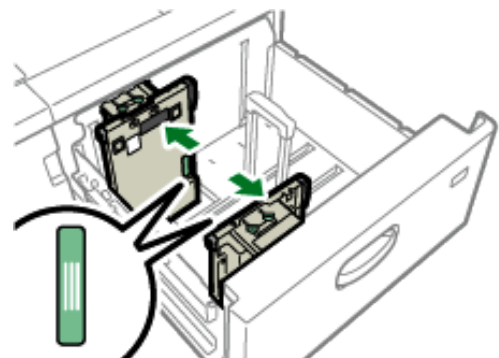

DCOMFC1287

Loading Paper into wide LCT

Step: 5

While pressing the release button of the end fence, slide the end fence outward.

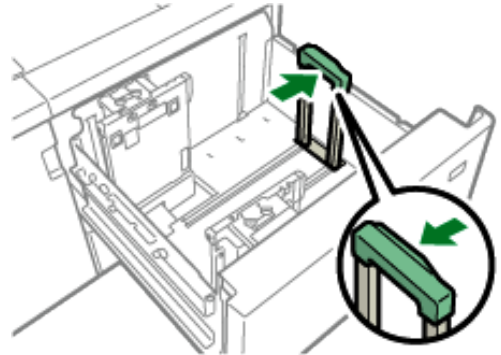

DDCM/C 1288

Step: 6

Load paper into the paper tray with print side up.

Load a stack of paper about 5–10 mm high, using the symbol at the bottom of the side fence as a guide.

Make sure that the paper rest on top of the supporting plates on both sides.

Set the paper flush against the left fence and align the paper edges.

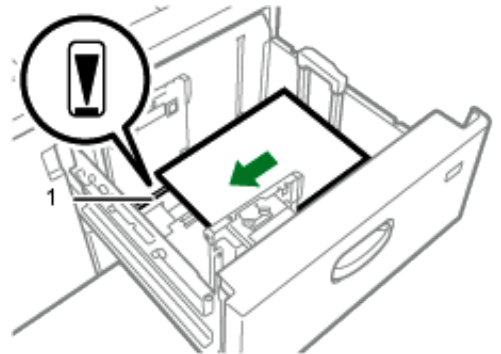

DDCM/C 1289

1. Supporting Plate

Step: 7

Holding the labeled parts of the side fences, adjust the fences to the paper size.

Set the paper flush against the protrusions in the bottom of the inner side fence. Make sure that there is no space between the paper and the side fences.

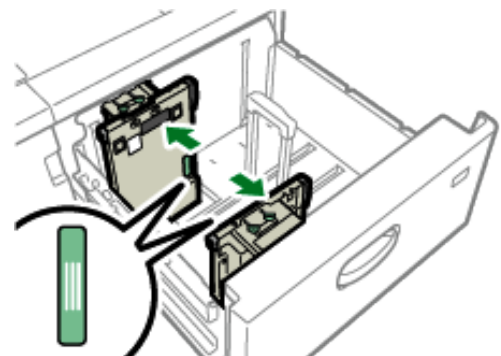

DDCM/C 1287

Loading Paper into wide LCT

Check that the positions of the scale numbers on the top of both of the side fences are almost the same. When loading regular size paper, align the screw holes on the side fences to the paper size mark.

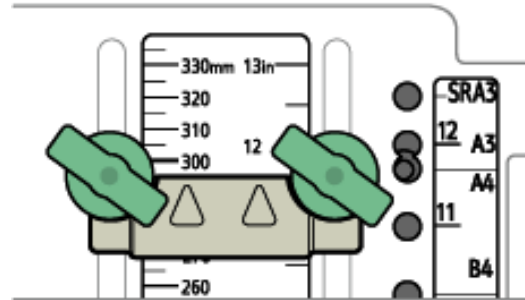

DDM/C 1291

Step: 8

Hold the inner side fence, and then tighten the screws to the inner side fence.

Fasten the front side fence in the same way.

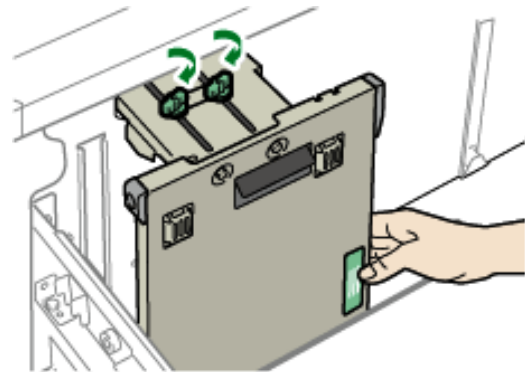

DDM/C 1292

Step: 9

Load additional sheets, if necessary.

Do not stack paper over the limit mark.

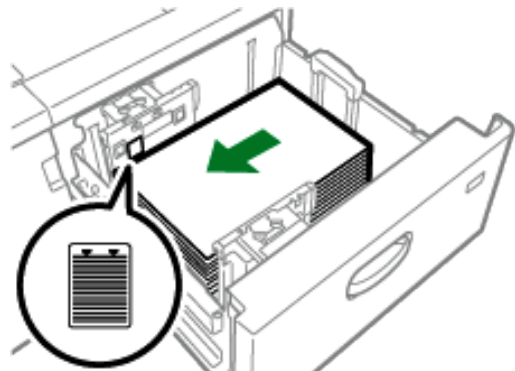

DDM/C 1293

Step: 10

While pressing the release button of the end fence, align the end fence gently against the paper you loaded.

Make sure that there is no space between the paper and end fence.

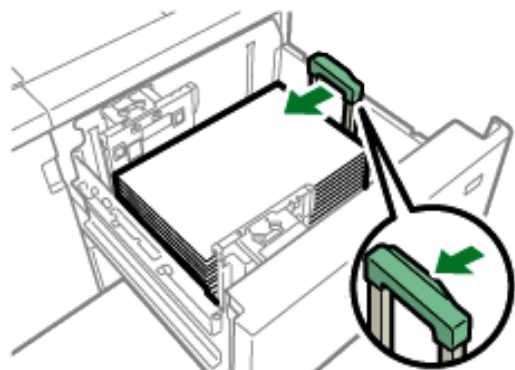

DDM/C 1294

Loading Paper into wide LCT

Step: 11

Carefully slide the paper tray fully in.

If you push the paper tray too forcefully when you put it back in place, the position of the paper might change and print accuracy becomes lower.

Step: 12

Specify the paper settings.

Note

If you select Paper Weight 6 to 9, [Coated Paper: High Gloss], [Coated: Glossy], [Coated: Matte], [Label Paper], or [Transparency] in [Tray Paper Settings], air is blown out automatically to fan the paper loaded in the wide LCT. Fan this paper before loading it.

Specifications.

Capacity: 2,200 sheets. (Capacity using 80 gsm uncoated paper).

Weight:	Paper weight 1: 52.3 to 65.9 gsm	Paper weight 5: 127.5 to 150.0 gsm
	Paper weight 2: 66.0 to 80.9 gsm	Paper weight 6: 150.1 to 216.0 gsm
	Paper weight 3: 81.0 to 100.9 gsm	Paper weight 7: 216.1 to 256.0 gsm
	Paper weight 4: 101.0 to 127.4 gsm	Paper weight 8: 256.1 to 300.0 gsm

Type: Plain Paper, Recycled Paper, Colour, Letterhead, Preprinted Paper, Prepunched Paper, Transparency, Translucent Paper, Label Paper, Coated: High Gloss, Coated: Glossy, Coated: Matte, Envelope: Glossy, Envelope: Matte, Envelope: High Gloss, Textured Paper, Magnet Paper, Metallic/Pearl Paper, Carbonless Paper, Synthetic Paper, Tab Stock.

Loading Tab Stock into the Wide LCT

When loading tab stock, attach the tab sheet fence.

Step: 1

Open the front cover of the wide LCT, and then take out the tab sheet fence.

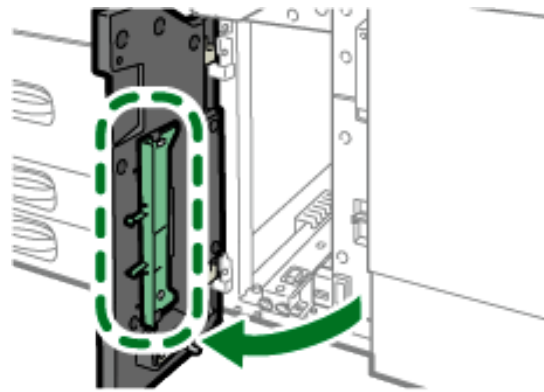

Step: 2

Close the front cover.

Step: 3

Check that paper in the paper tray is not being used, and then pull the tray carefully out until it stops.

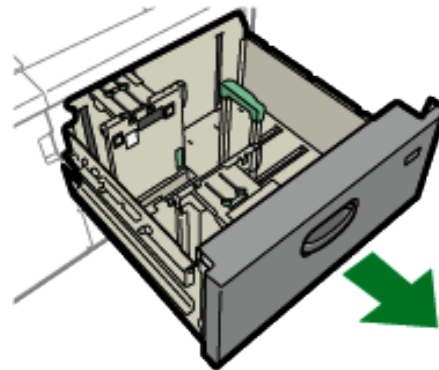

Step: 4

Set the side fences to the size of the tab stock to be loaded, and then load it.

Step: 5

Attach the tab sheet fence, and then align the end fence gently against the paper you loaded while pressing the release button of the end fence.

Carefully slide the paper tray fully in.

Specify the paper settings.

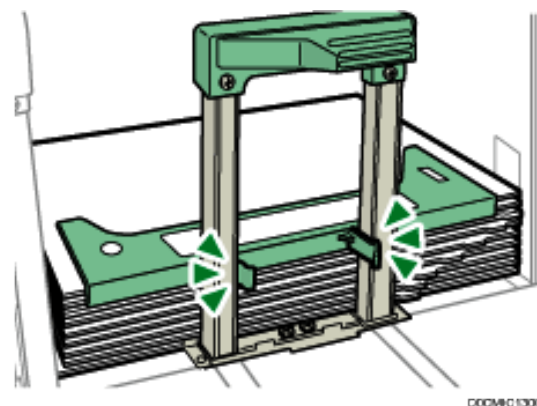

CIP Training Pro C5300 series

Loading Paper with a vertical size 100mm to 139.2mm in Wide LCT

When loading paper that is 100.0 to 139.2 mm in vertical length, attach the postcard side fences.

Step: 1

Open the front cover of the wide LCT, remove the screws from the postcard side fences, and then take them out.

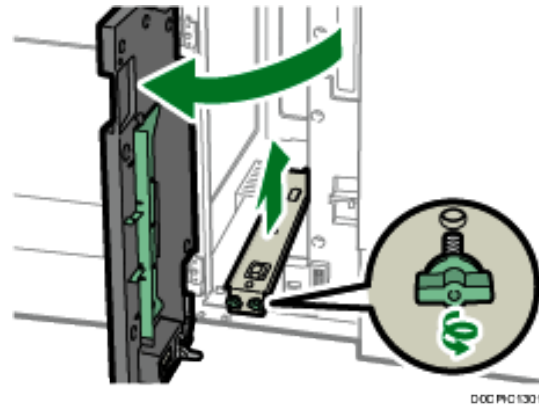

Step: 2

Close the front cover.

Step: 3

Check that paper in the paper tray is not being used, and then pull the tray carefully out until it stops.

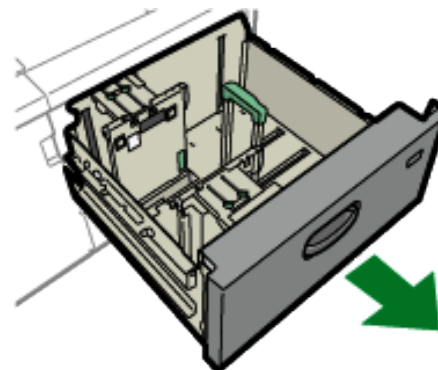

Step: 4

Fit the indentation on the bottom of the postcard side fence with the limit mark into the head of the screw on the bottom of the inner side fence.

Step: 5

Fit the hole on the top of the postcard side fence into the projection on the top of the side fence.

Set the other postcard side fence to the front side fence in the same way.

CIP Training Pro C5300 series

Loading Paper with a vertical size 100mm to 139.2mm in Wide LCT

Step: 6

Fasten the postcard side fences with the screws.

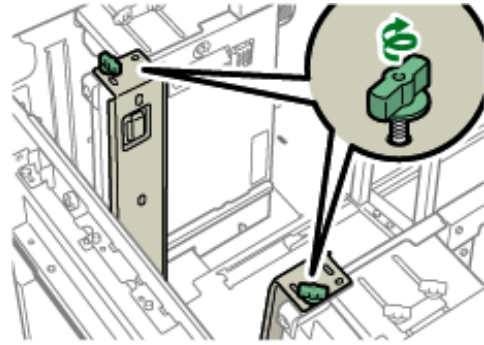

Step: 7

Align the end fence and side fences with the paper size to be loaded, and then load the paper.

Step: 8

Carefully slide the paper tray fully in.

Step: 9

Specify the paper settings.

Note

Replace the postcard side fences after use.

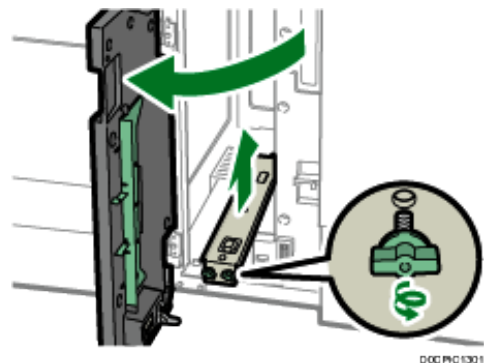

Loading Paper into the Two-tray Wide LCT

The two-tray wide LCT is identified as Tray T1 and T2.

- To use carbonless paper, the optional carbonless paper unit is required.

Step: 1

Check that paper in the paper tray is not being used, and then pull the tray carefully out until it stops.

Remove paper if loaded.

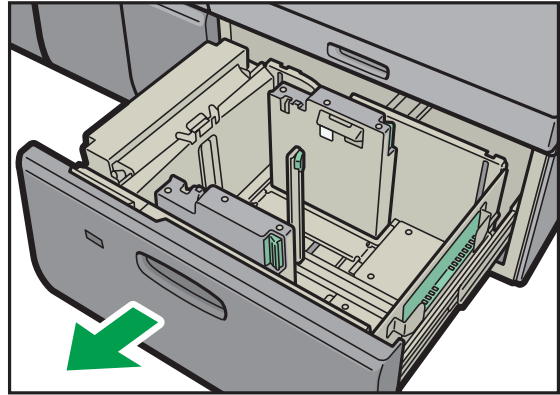

Step: 2

Release the end fence by pressing and holding green button. Move to back of tray.

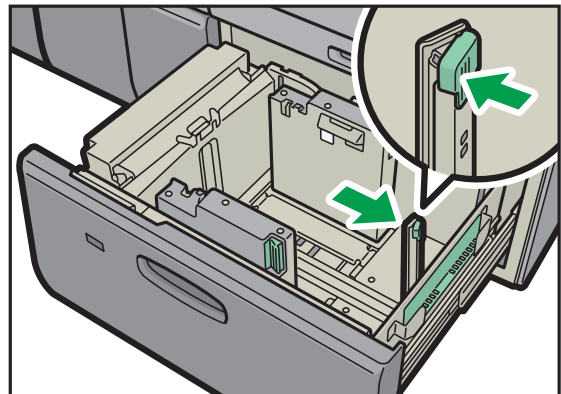

Step: 3

Release the side fence by pressing and holding both green buttons together. Move side fences to maximum width of tray.

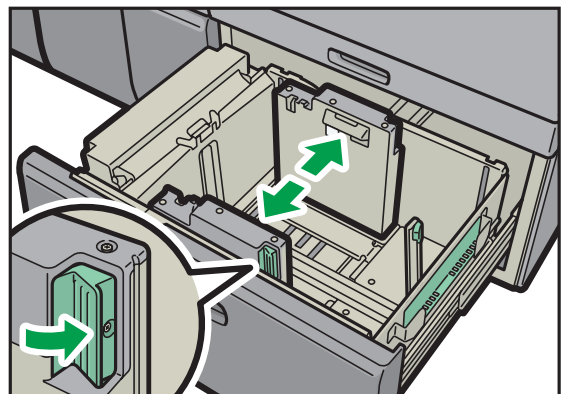

Loading Paper into the Two-tray Wide LCT

Step: 4

Load paper by aligning the paper with the left side of the paper tray.
Place paper with print side up.
Load a stack of paper about 5–10 mm high.
Make sure the paper rest on top of the supporting plates on both sides.

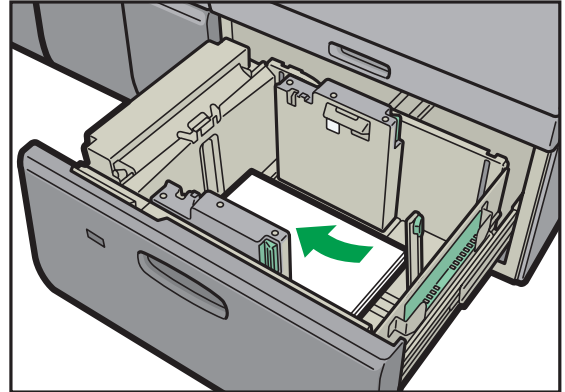

Step: 5

Load additional sheets, if necessary.
Do not stack paper over the limit mark.

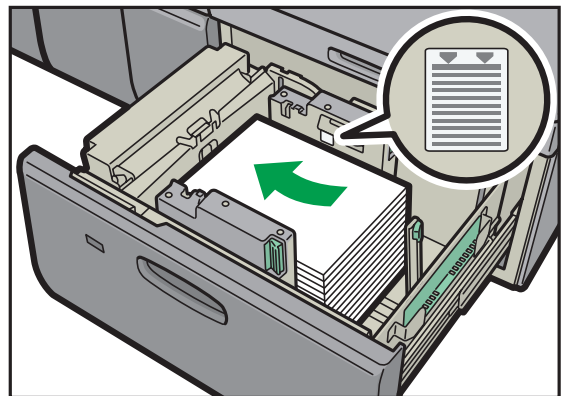

Step: 6

Tightly fit the end fence to the loaded paper, and then re-lock the end fence again.

Make sure there are no gaps between the paper and end fence.

Carefully slide the paper tray fully in.

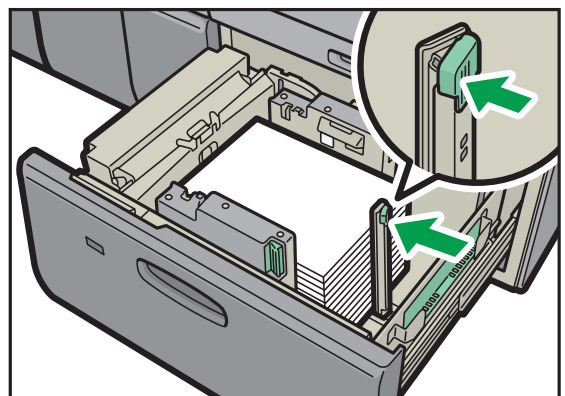

Loading Paper into the Two-tray Wide LCT

When loading small stock.

When you load paper that is 204 mm or smaller, remove the supporting plates from the bottom of the paper tray.

Store them in the pocket on the right-hand side of the paper tray.

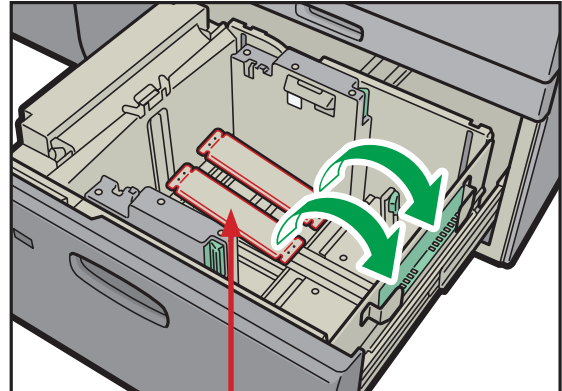

Supporting plates

Set the paper flush against the protrusions in the bottom of the inner side fence.

Check that the scale numbers on the top of the side fences are roughly the same.

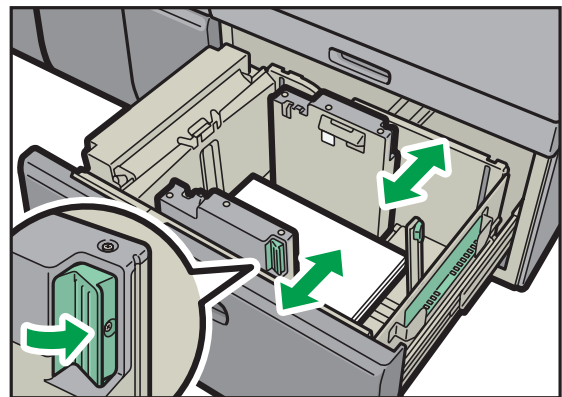

Specifications.

Capacity: 2 x 2,200 sheets. (Capacity using 80 gsm uncoated paper)

Weight:

Paper weight 1: 52.3 to 65.9 gsm	Paper weight 6: 150.1 to 216.0 gsm
Paper weight 2: 66.0 to 80.9 gsm	Paper weight 7: 216.1 to 256.0 gsm
Paper weight 3: 81.0 to 100.9 gsm	Paper weight 8: 256.1 to 300.0 gsm
Paper weight 4: 101.0 to 127.4 gsm	Paper weight 8: 300.1 to 360.0 gsm
Paper weight 5: 127.5 to 150.0 gsm	

Type: Plain Paper, Recycled Paper, Black, Color, Letterhead, Preprinted Paper, Prepunched Paper, Transparency, Translucent Paper, Label Paper, Coated: High Gloss, Coated: Glossy, Coated: Matte, Envelope: Glossy, Envelope: Matte, Envelope: High Gloss, Textured Paper, Magnet Paper, Metallic/Pearl Paper, Clear File Folder, Carbonless Paper, Synthetic Paper, Tab Stock: Glossy, Tab Stock: Matte, Tab Stock: High Gloss.

Loading Paper into the Two-tray Wide LCT

When loading tab stock, attach the tab fence.

Step: 1

Check that paper in the paper tray is not being used, and then pull the tray carefully out until it stops.

Take out the tab fence from the pocket on the right-hand side of the paper tray.

Set the side fences to the size of the tab stock to be loaded, and then load it.

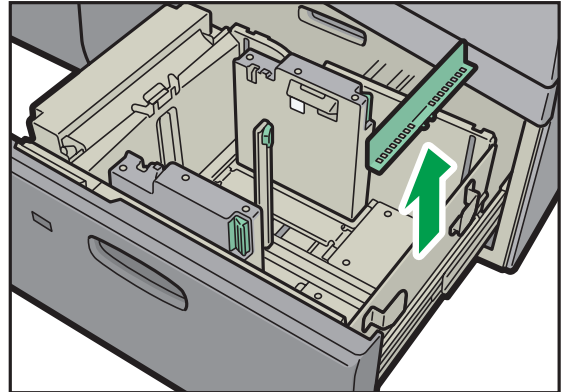

Step: 2

Attach the tab fence, and then align the end fence gently against the paper you loaded while pressing the release button of the end fence.

Carefully slide the paper tray fully in.

NOTE: Replace the tab fence after use.

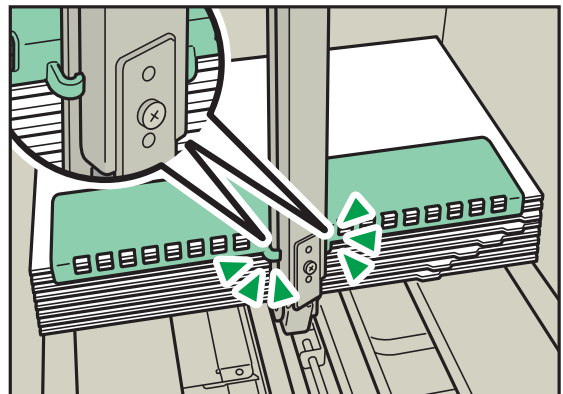

RICOH
imagine. change.